

Tubular Single Stand Step-by-Step Instructions

SD-FPT-001-CHR & SD-FPT-001-RED

Positioning the Parts

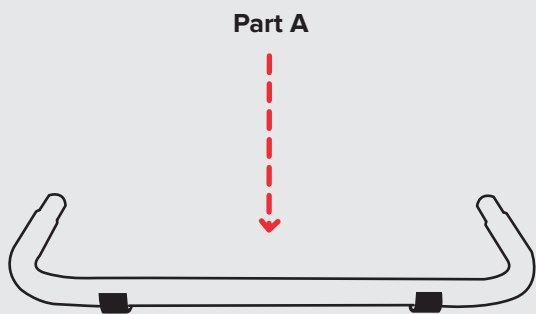

1. Take Part A, and lay flat on the floor, position the rubber feet floor down for stability.

Pushing Together

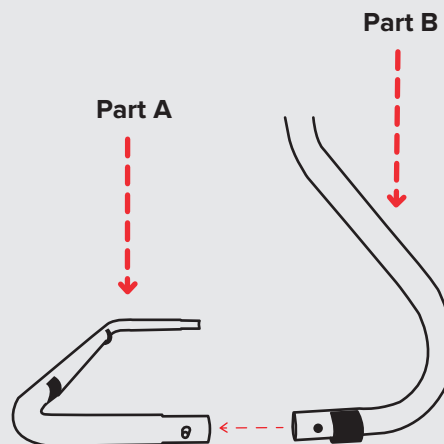

2. Line up the outside hole of Part B with Part A, pushing the popper in so that it clicks into position. Repeat with Part C.

Repeat

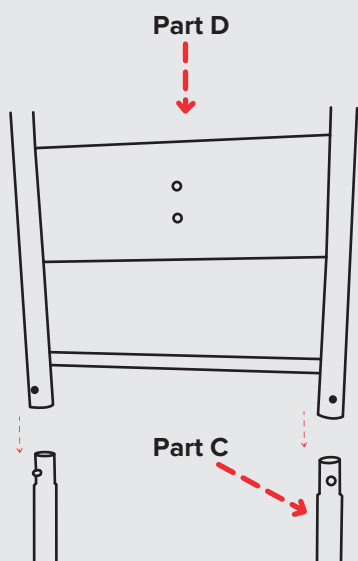

3. Taking Part D, line up with Parts B and C, pushing in the poppers so that it once again clicks into position.

Final Step

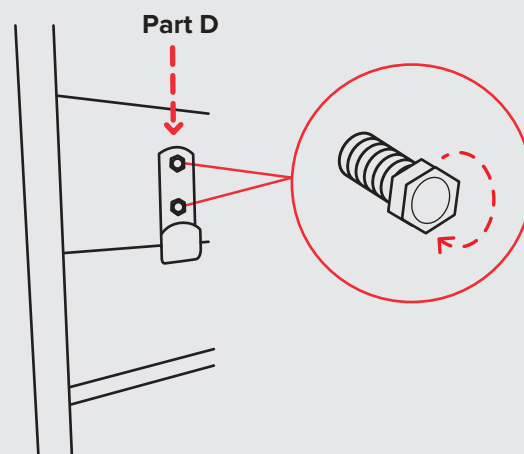

4. Install Part E as demonstrated.